

DMF-50051N-SEW

PRODUCT SPECIFICATIONS

OPTREX TYPE No. : DMF-50051N-SEW

This specification is subject to change.
Please consult OPTREX to verify whether any changes
occur in the specification before starting your production.

REVISION No. 1 : APR. 8. ' 94

OPTREX CORPORATION

1. Scope

This specification covers the technical data of the undermentioned Liquid Crystal Display(LCD)Module which is delivered from Optrex Corporation to Messrs.

2. Product

Liquid Crystal Display (LCD) Module.

3. Type No.

CLIENT Type No. : _____

OPTREX Type No. : DMF-50051N-SEW

4. General Specifications

Operating Temp. : min. 0 °C ~ max. 50 °C
Storage Temp. : min. -20 °C ~ max. 60 °C
Dot Pixels : 128 (W) × 64 (H) dots
Dot Size : 0.40 (W) × 0.56 (H) mm
Dot Pitch : 0.44 (W) × 0.60 (H) mm
Viewing Area : 62.0 (W) × 44.0 (H) mm
Outline Dimensions : 78.0 (W) × 80.0 (H) × 10.3 MAX.(D) mm
LCD Type : NTN / Neutral-mode / Transflective
Viewing angle : 6:00
Data Transfer : 1 bit serial data transfer
Back-light : Electro Luminescence (EL) / Color : White
Drawings : Dimensional Outline UE-20526B

5. Electrical Specifications

5.1 Absolute Maximum Rating

$V_{SS} = 0V$

ITEM	SYMBOL	CONDITION	MIN.	MAX.	UNIT
Supply Voltage (Logic)	V_{CC} $- V_{SS}$	—	-0.3	7.0	V
Supply Voltage (LCD Drive)	V_{CC} $- V_{EE}$	—	V_{CC} +0.3	28.0	V
Input Voltage	V_I	—	-0.3	V_{CC} +0.3	V

5.2 Electrical Characteristics

$T_a = 25^\circ C, V_{CC} = 5.0V \pm 10\%, V_{SS} = 0V$

ITEM	SYMBOL	CONDITION	MIN.	TYP.	MAX.	UNIT
Supply Voltage (Logic)	V_{CC} $- V_{SS}$	—	4.5	—	5.5	V
Supply Voltage (LCD Drive)	V_{CC} $- V_{EE}$	Shown in 6.1				V
Input Voltage 'H' Level	V_{IH}	—	V_{CC} -0.8	—	V_{CC}	V
Input Voltage 'L' Level	V_{IL}	—	0	—	0.8	V
Power Supply Current	I_{CC}	—	—	—	10.0	mA
	I_{EE}	—	—	—	5.0	mA

5.3 Timing Characteristics

5.3.1 AC Electrical

$V_{CC}=5V \pm 10\%$

ITEM	SYMBOL	MIN.	MAX.	UNIT
CP Pulse Width	t_{CWH}, t_{CWL}	95	-	n S
CP Clock Rise / Fall Time	t_r, t_f	-	30	n S
LP Pulse Time	t_{LW}	70	-	n S
LP Hold Time	t_{LFP}	75	-	n S
LP Set up Time	t_{LRP}	40	-	n S
Data Set up Time	t_{DSU}	50	-	n S
Data Hold Time	t_{DH}	60	-	n S
Frame Data Set up Time	t_{FDS}	5	-	n S
Frame Data Hold Time	t_{FDH}	25	-	n S

During Latch Pulse is "H" level, Please make sure to keep Clock Pulse in "L" level.

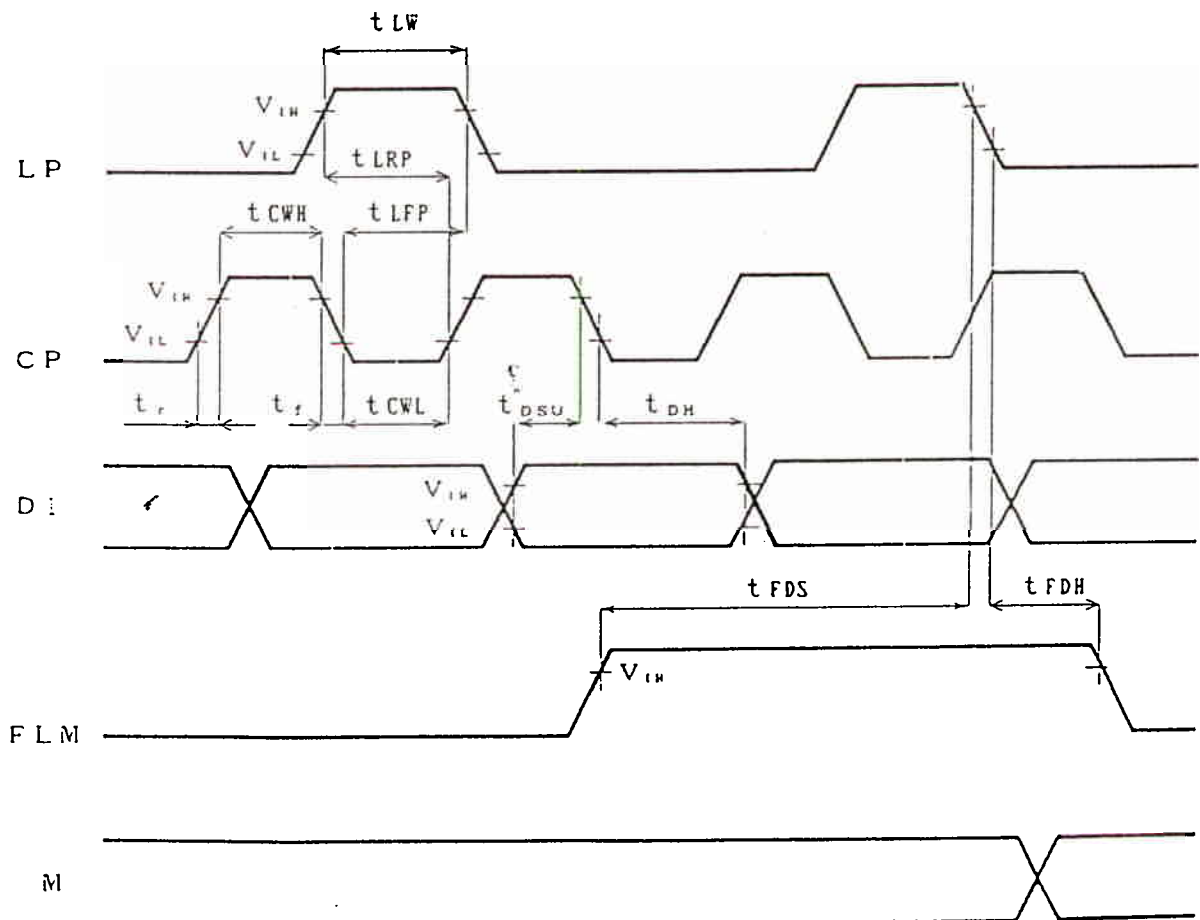

5.3.2 Timing Chart

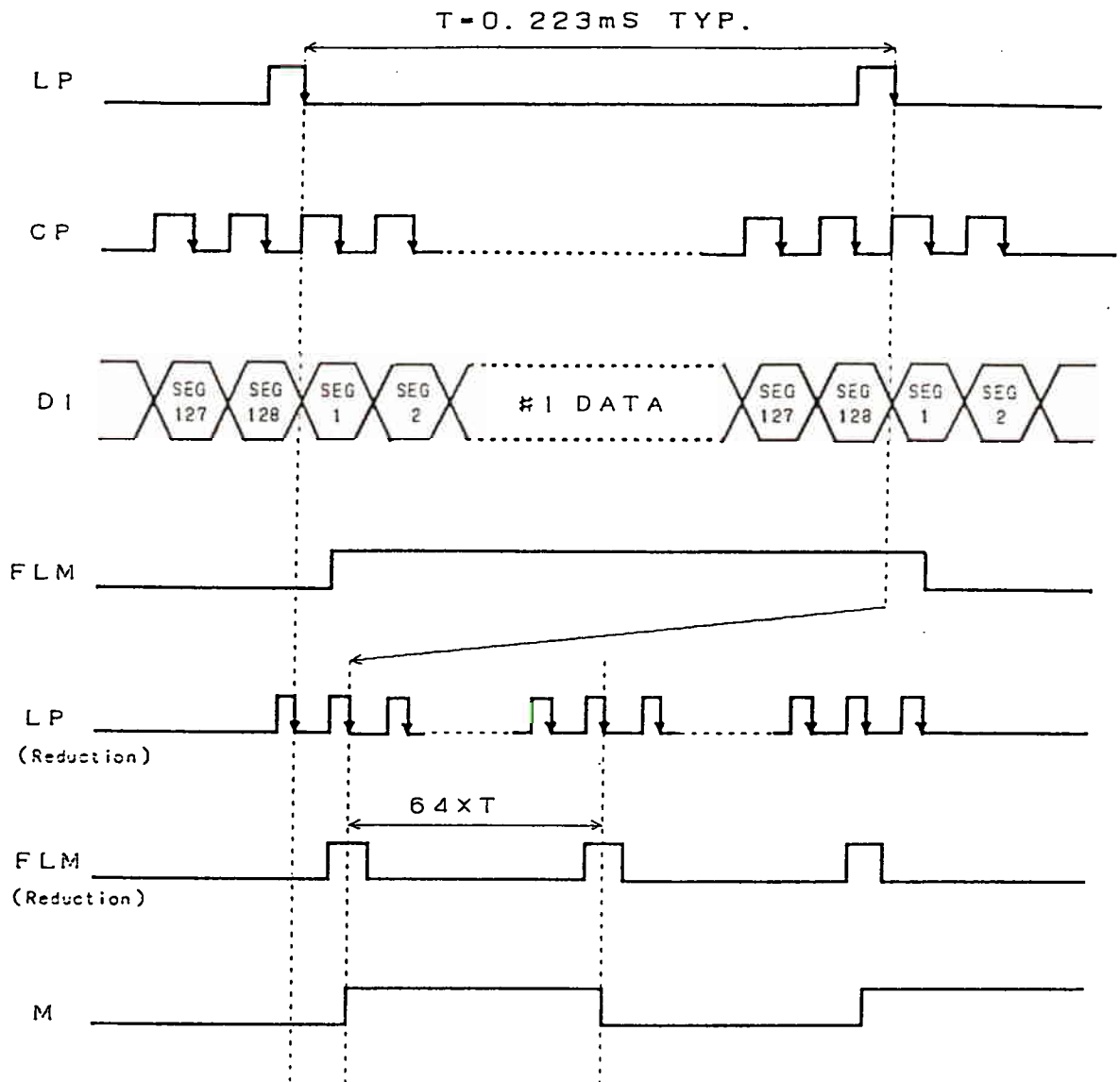

5.3.3 Comparison of Display and Data

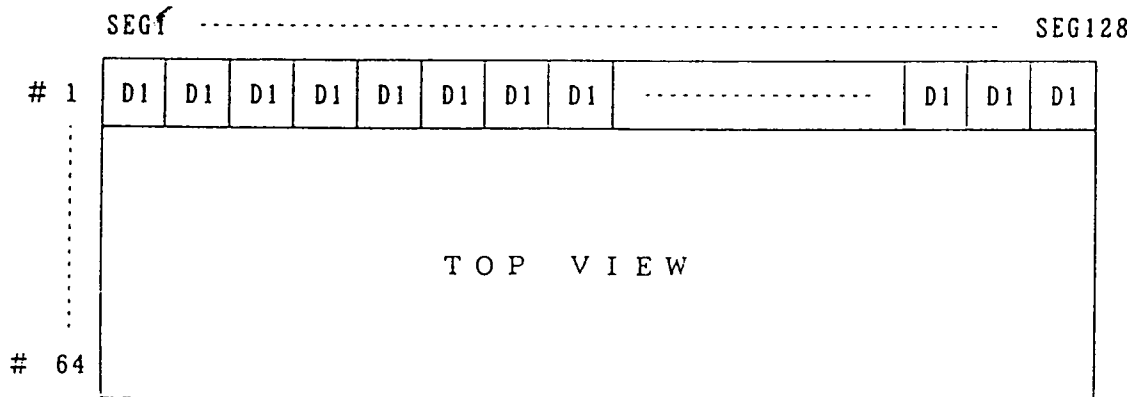

5.4 Power Supply ON/OFF sequence

5.4.1 ON sequence

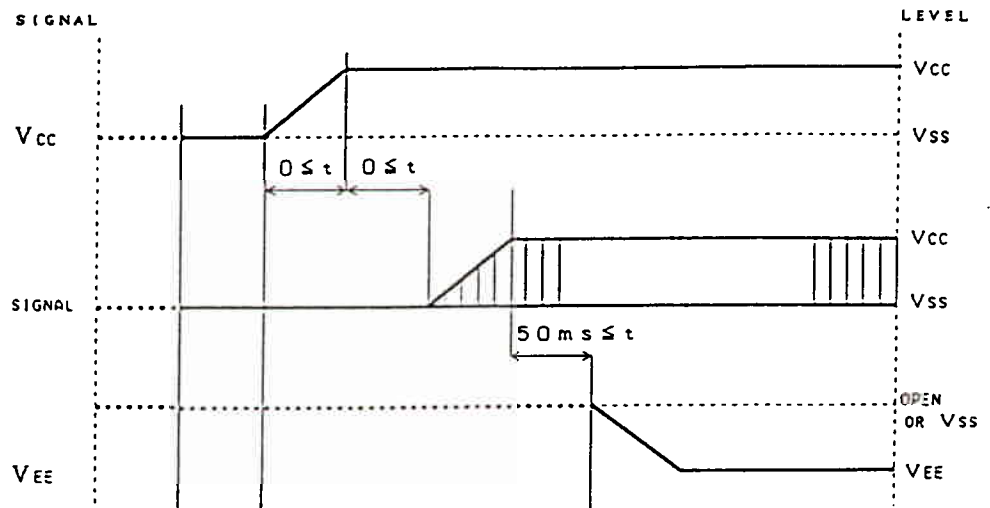

5.4.2 OFF sequence

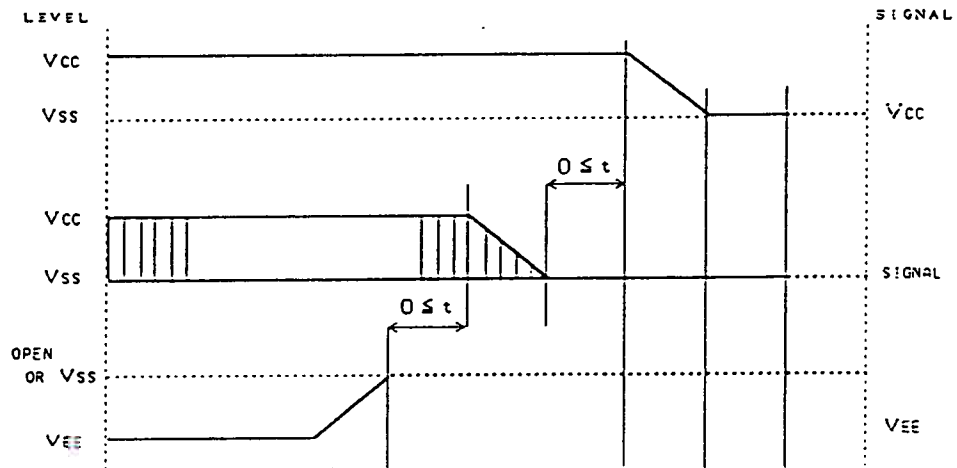

Please maintain the above sequence when turning on and off the power supply of the module.

While alternate signal for LCD driving (M signal) is unstable if V_{EE} is supplied to the module, DC component will be supplied to the LCD panel.

This may cause damage the LCD module.

5.5 EL Specification

5.5.1 Absolute Maximum Rating

$T_a = 25^\circ\text{C}$

ITEM	CONDITION	MIN.	TYP.	MAX.	UNIT
Input Voltage	—	—	—	150	V _{rms}
Input Frequency	—	—	—	800	H z

5.5.2 Operating Characteristics

$T_a = 25^\circ\text{C}$

ITEM	CONDITION	MIN.	TYP.	MAX.	UNIT
Input Voltage	—	—	100	—	V _{rms}
Input Frequency	—	—	400	—	H z
Current	AC100Vrms400Hz	—	3.2	4.2	m A
Life	AC100Vrms400Hz Ta=20°C, 60%RH	2000	—	—	H r s

Recommendation Inverter : NEC No. NEL-D32-43 (DC $5.0\text{V} \pm 10\%$)

6. Optical Specifications

6.1 Optical Specifications

$T_a=25^{\circ}\text{C}, V_{CC}-V_{EE}:13.0\text{V}, \theta = 0^{\circ}, \phi = -^{\circ}$

ITEM	SYMBOL	CONDITION	MIN.	TYP.	MAX.	UNIT	
Recommended LCD Driving Voltage (1/ 64 Duty)	$V_{CC}-V_{EE}$	$T_a = 0^{\circ}\text{C}$	-	-	15.3	V	
		$T_a = 25^{\circ}\text{C}$	-	13.0	-	V	
		$T_a = 50^{\circ}\text{C}$	10.9	-	-	V	
Contrast Ratio	CR	Note1 $\theta = 0^{\circ}, \phi = -^{\circ}$	-	4	-		
Viewing Angle		Shown in 6.2					
Response Time	Rise	τ_r	Note2 $T_a=25^{\circ}\text{C}$	-	160	240	m S
	Decay	τ_d	Note3 $T_a=25^{\circ}\text{C}$	-	160	240	m S

Note1 : Definition of Contrast Ratio

When brightness of non-selected signal was A and brightness of selected signal was B, contrast ratio defined

$CR=A/B$ (Positive Case)

$CR=A/B$ (Negative Case)

Note2 : The time of that the brightness level reaches 90% level of the saturation level from 0% level when ON signal is applied.

Note3 : The time of that the brightness level reaches 10% level of the saturation level from 100% level when OFF signal is applied.

6.2 Definition of Viewing Angle and Optimum Viewing Area

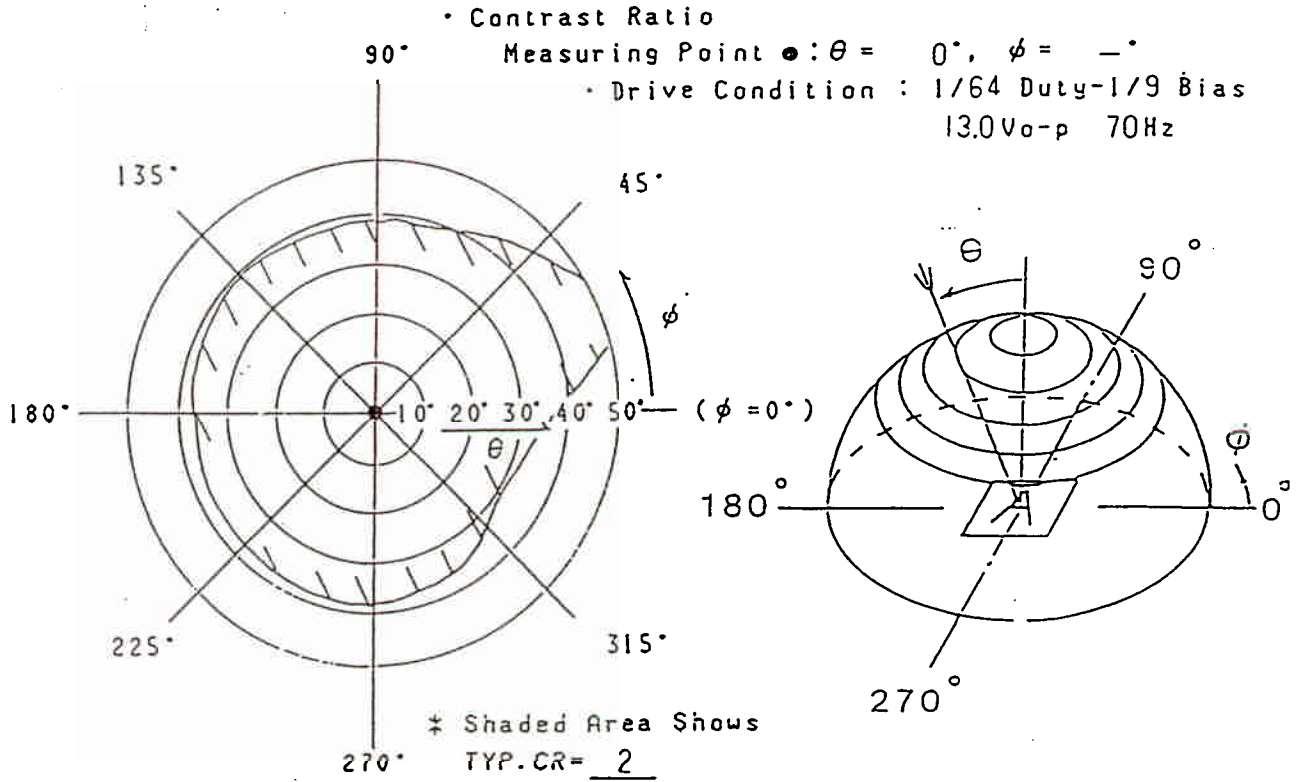

6.3 System Block Diagram

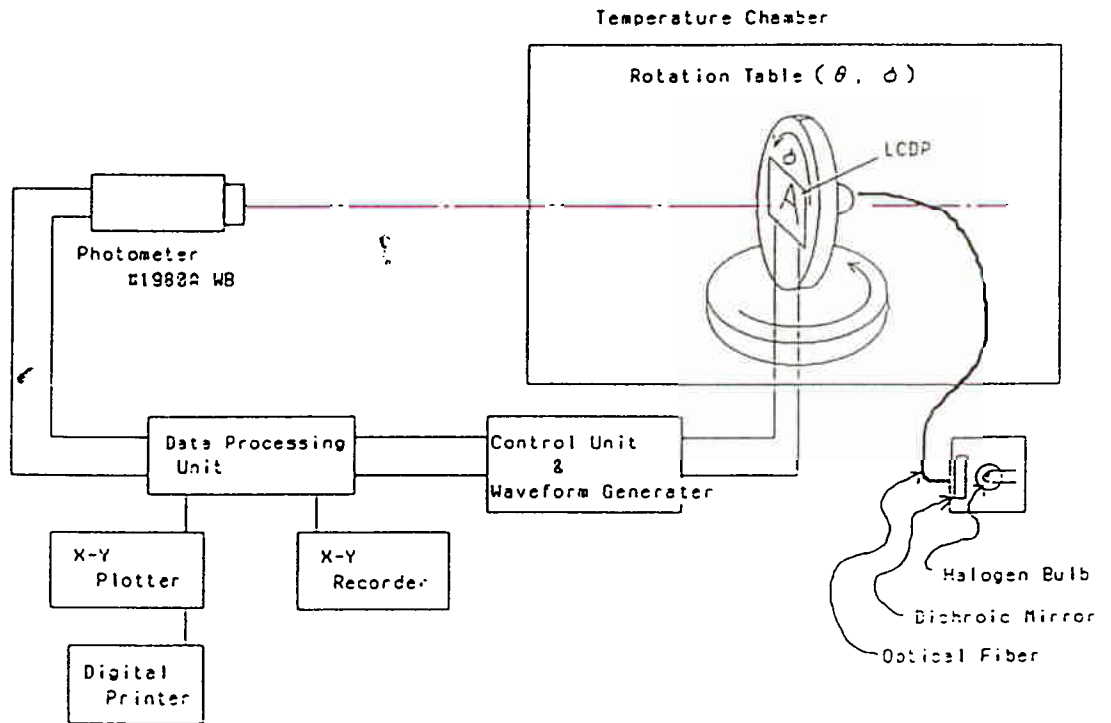

7. I/O Terminal

7.1 Pin Assignment

CN1

PIN NO.	SYMBOL	LEVEL	FUNCTION
1	EL	—	Power supply for EL
2	EL	—	Power supply for EL

CN2

PIN NO.	SYMBOL	LEVEL	FUNCTION
1	FLM	H/L	First Line Marker
2	LP	H→L	Data Latch Signal
3	CP	H→L	Clock Signal for Shifting Data
4	M	H/L	Alternate Signal for LCD Drive
5	V _{CC}	—	Power Supply for Logic (+5V)
6	V _{SS}	—	Power Supply (0V, GND)
7	V _{EE}	—	Power Supply for LCD Drive
8	D1	H/L	Display Data
9	NC	—	Non connection
10	NC	—	Non connection

H:V_{CC} Level L:V_{SS} Level

7.2 Example of Power Supply

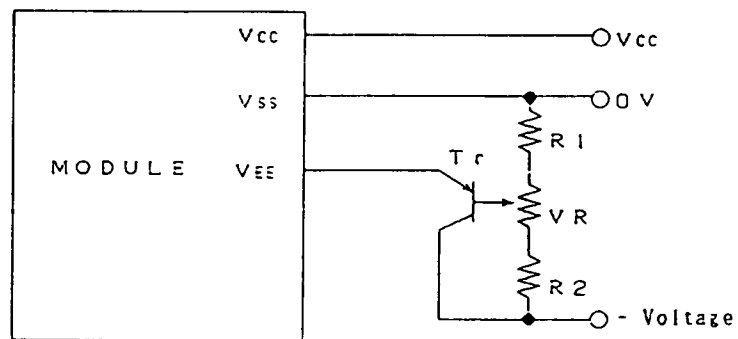

$$R1 + R2 + VR = 10 \sim 20 \text{ k}\Omega$$

$$Tr = 2SA1202 \text{ or Equivalent}$$

7.3 Pin No. Layout

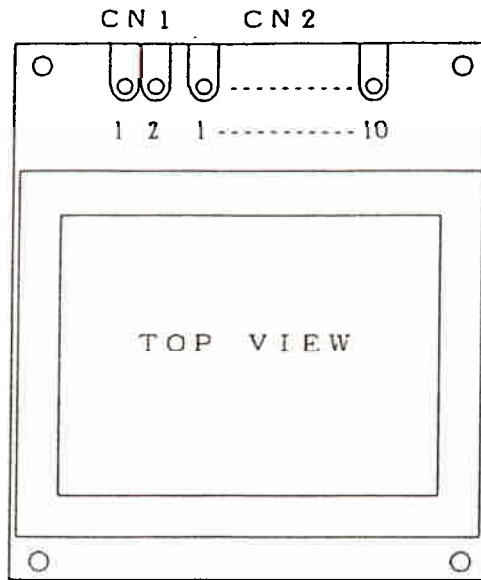

7.4 Block Diagram

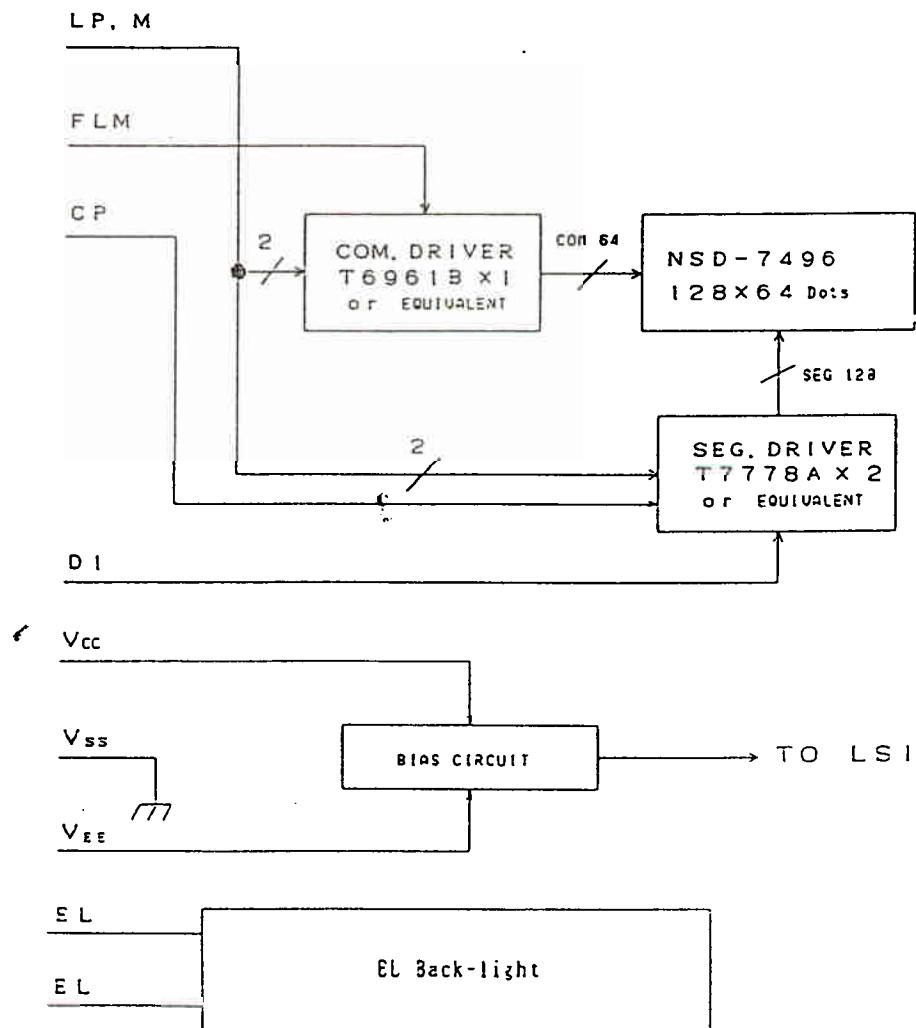

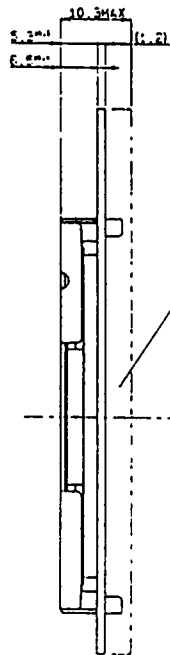
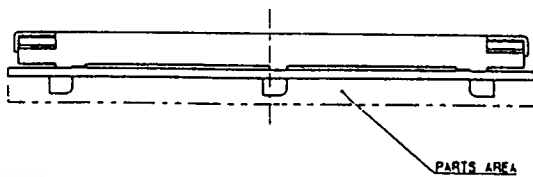
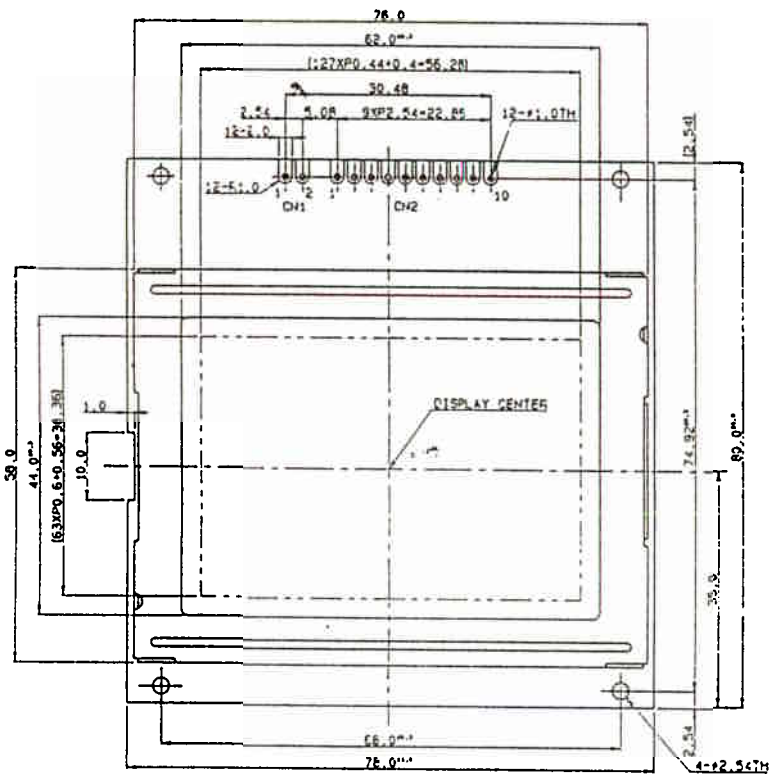

PIN ASSIGNMENT

Q11

PIN NO.	SYMBOL
1	EL
2	EL

Q12

PIN NO.	SYMBOL
1	FLM
2	LP
3	CP
4	H
5	VCC
6	VSS
7	VEE
8	D1
9	HC
10	HC

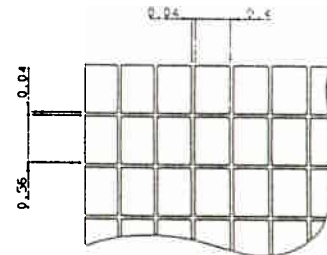

DOT DETAIL SCALE: 25/1

NO.	DATE	BY	CHKD	APP'D
1	02.10.11	S. HIZOBUCHI		
2	02.10.11	S. HIZOBUCHI		
3	02.10.11	S. HIZOBUCHI		
4	02.10.11	S. HIZOBUCHI		
5	02.10.11	S. HIZOBUCHI		

NO.	DATE	REVISIONS	BY	CHKD	APP'D
1					
2					
3					
4					
5					

MATERIAL	FINISH	SCALE	NOTE
3rd ANGLE PROJECTION	TOLERANCE CLASS B	SCALE 2/1	
APPROVED FILE & C.L.T.	MODEL	DMF50051N EL Series	
DESIGNED BY S. HIZOBUCHI	TITLE	DIMENSIONAL OUTLINE	
DATE	REVISIONS	BY	CHKD
OPTREX CORPORATION		DESIGNED BY S. HIZOBUCHI	DRAWING NO. UE-20526B